

# BenchMark® MSC-30 Mobile Scale Cart



## Standard Features

---

- Two swivel, locking casters and two rigid casters
- Indicator stand for mounting CW-90/90X, 480/480Plus, 482/482Plus, 680/682 Synergy, 380/380X Synergy

# Mobile Bench Scale Cart

The BenchMark MSC mobile scale carts are ideal for applications where bench scale portability is necessary. The cart is designed with two rigid and two swivel casters with locking wheel brakes. With an stand to help move the cart and mount the weight indicator, weight readings will be easily visible to the operator.

## BenchMark MSC-30 Mobile Scale Cart Specifications

**Capacity:**  
1,000 lb (500 kg) maximum

**Warranty:**  
One-year limited

## BenchMark MSC-30 Mobile Scale Cart Dimensions

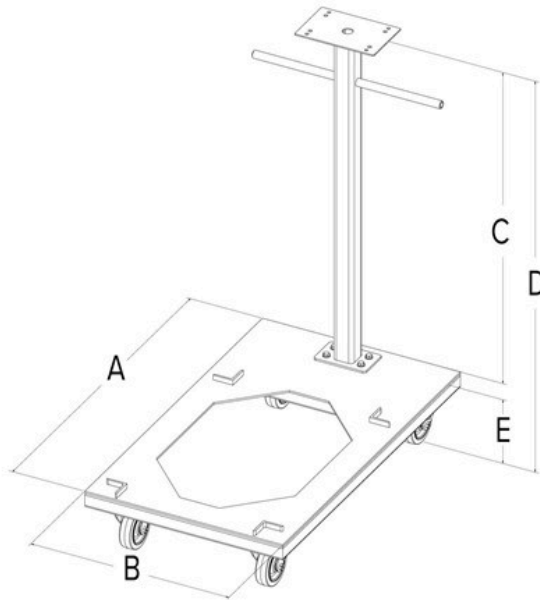

Dimensions					
	A	B	C	D	E
Designed for 12 × 18 in scale	30.00 in	20.00 in	34.25 in	41.00 in	6.81 in
Designed for 18 × 18 in scale	30.00 in	20.00 in	34.25 in	41.00 in	6.81 in
Designed for 18 × 24 in scale	35.00 in	20.00 in	34.25 in	41.00 in	6.81 in
Designed for 24 × 24 in scale	35.00 in	26.00 in	34.25 in	41.00 in	6.81 in

*Note: 1 in = 25.4 mm*

## Parts

---

Part #	Description
<b>Mild Steel</b>	
197510	Cart, Benchmark MSC-30 mild steel designed for 12x18 scale
197511	Cart, Benchmark MSC-30 mild steel designed for 18x18 scale
197512	Cart, Benchmark MSC-30 mild steel designed for 18x24 scale
197513	Cart, Benchmark MSC-30 mild steel designed for 24x24 scale
<b>Stainless Steel</b>	
197514	Cart, Benchmark MSC-30 stainless steel designed for 12x18 scale
197515	Cart, Benchmark MSC-30 stainless steel designed for 18x18 scale
197516	Cart, Benchmark MSC-30 stainless steel designed for 18x24 scale
197517	Cart, Benchmark MSC-30 stainless steel designed for 24x24 scale

**[www.ricelake.com](http://www.ricelake.com) | 800-472-6703**

*An ISO 9001 Registered Company ©2024 Rice Lake Weighing Systems*