

# RoughDeck® HP Caster SENDit Portability Frames, Non-NTEP



*As of: Thursday, February 13,  
2025*



## Standard Features

---

- Wireless connection from scale to operator display
- Works with any basic digital weight indicator
- Excitation to the load cell(s) provided by the transmitter, not the indicator
- Each transmitter/receiver set is individually paired and will not interfere with another set
- Transmitter excitation voltage: +4.8 VDC, 16 × 350 ohm or 32 × 700 ohm load cells



# RoughDeck HP SENDit Portability Frames Dimensions

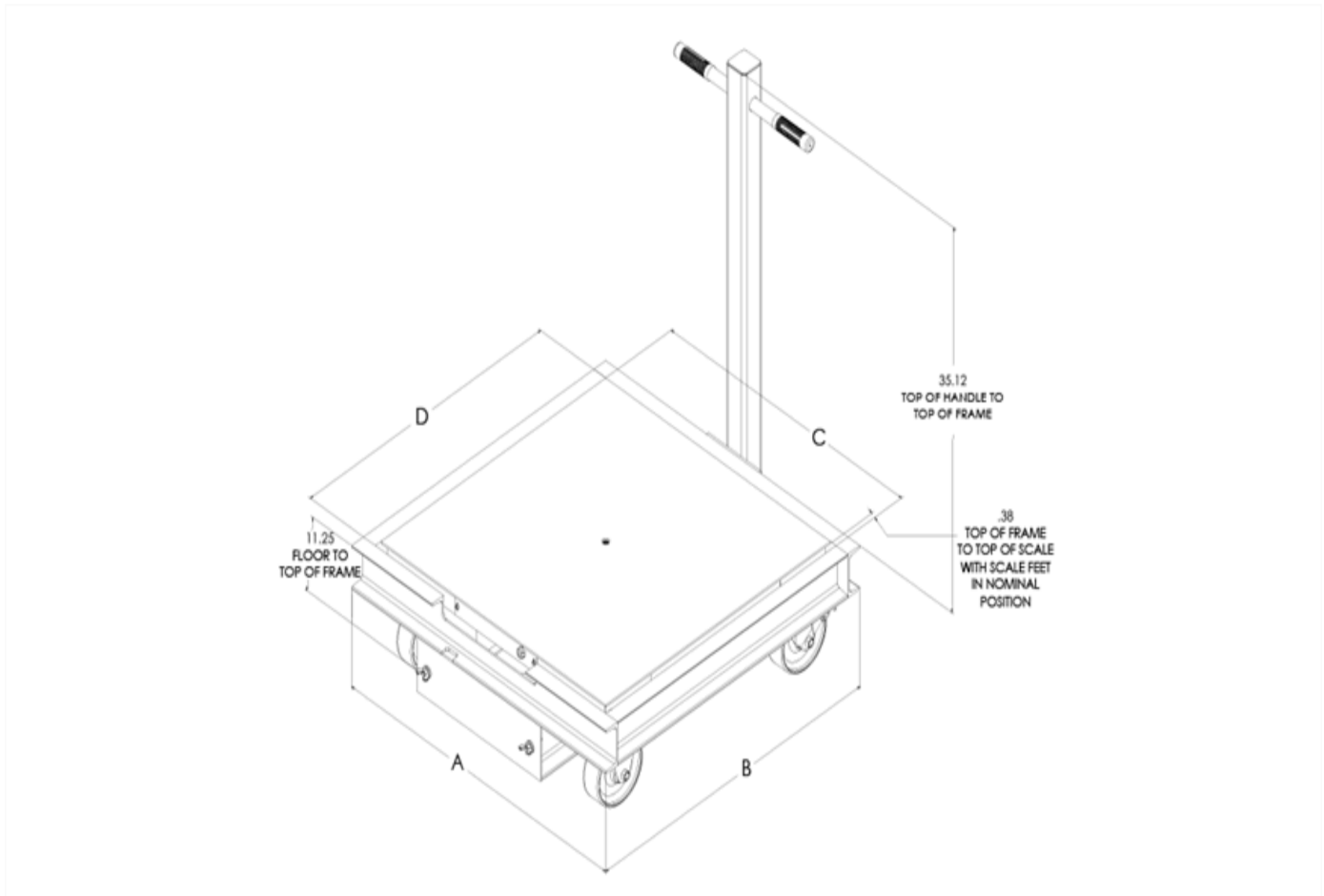

Drawing Dimensions			
Scale Size	2.5 × 2.5 ft	3 × 3 ft	4 × 4 ft
A	33.92 in	39.92 in	51.92 in
B	33.92 in	39.92 in	51.92 in
C	30.75 in	36.75 in	48.75 in
D	30.75 in	36.75 in	48.75 in

# Parts

---

<b>Part #</b>	<b>Description</b>
---------------	--------------------

## **RoughDeck HP Portability Frame**

- |               |  |
|---------------|--|
| <b>210902</b> | Caster Portability Frame Roughdeck 2.5 x 2.5 mild steel 1K to 5K, Electronics not included Two rigid forged steel caster on the front, Two swivel forged steel casters with lock on the back, with drawer for SENDit |
| <b>210903</b> | Caster Portability Frame Roughdeck 3 x 3 mild steel 1K to 5K, Electronics not included Two rigid forged steel caster on the front, Two swivel forged steel casters with lock on the back, with drawer for SENDit     |
| <b>210904</b> | Caster Portability Frame Roughdeck 4 x 4 mild steel 1K to 5K, Electronics not included Two rigid forged steel caster on the front, Two swivel forged steel casters with lock on the back, with drawer for SENDit     |
| <b>210905</b> | Caster Portability Frame Roughdeck 4 x 4 mild steel 10K, Electronics not included Two rigid forged steel caster on the front, Two swivel forged steel casters with lock on the back, with drawer for SENDit          |

## **SENDit Wireless Electronics Kit**

- |               |  |
|---------------|--|
| <b>210898</b> | Sendit Wireless Load Cell Interface Kit, non-nstep, customer to supply indicator, works with Portability Frame with drawer |
|---------------|--|

**[www.ricelake.com](http://www.ricelake.com) | 800-472-6703**

*An ISO 9001 Registered Company ©2024 Rice Lake Weighing Systems*