

# CW-90 Over/Under Checkweigher

**RICE LAKE**  
WEIGHING SYSTEMS

*As of: Wednesday, February  
12, 2025*



## Standard Features

---

- Membrane keypad consisting of: zero, units, print, tare, over, under, ID, target, 0-9, clear, decimal, enter, menu, power
- 304 stainless steel, IP66 rated indicator
- PreVent™ breather vent
- Storage for up to 50 IDs

## Approvals



- Unit of measure: kg, gm, lb, oz, lb/oz (lb/oz is not Legal for Trade)
- High-intensity LED display
- Battery backed time and date
- Two full-duplex RS-232 serial ports
- Configurable print formats
- Audit trail tracking
- Optional communications: Ethernet, USB or fiber-optic
- Four configurable Digital I/O
- Reflash memory to upgrade firmware
- Auto-print capability
- Accumulator
- Factory calibrated

Measurement  
Canada  
Approved



EU  
LEGAL  
FOR TRADE  
CERTIFIED



### Scale

- Aluminum, environmentally sealed load cell
- 304 stainless steel
- Meets HACCP requirements
- Five-point overload protection



WARNING:  
Cancer  
and  
Reproductive  
Harm  
California  
Proposition  
65

# The Checkweigher of Choice

---

Rice Lake's CW-90 checkweigher is designed to help speed up your weighing process and reduce production downtime, two critical factors to your company's bottom line. Ease of use, real-time data collection, and rugged stainless steel construction make the CW-90 the equipment of choice for operators, quality control and maintenance departments. The CW-90 is competitively priced for all light industrial settings.

## Easy to Configure

The configuration menu of the CW-90 is accessible through the front keypad, eliminating the need to open the back of the indicator and expose the unit to moisture or contaminants. Access to these keypad controls can be limited to meet the operator's needs. The CW-90 will store detailed information for up to 50 separate IDs, allowing for easy recall of previously saved information. An adjustable contrast display is visible in any environment.

## Simple to Maintain

The CW-90 has kept things simple to meet the needs of today's lean manufacturers. Use this checkweigher by easily watching the over/under lights. Program the unit with specified weight limits and a red light will display an underweight condition, yellow for over, and green when a target weight is reached. Rice Lake's CW-90 will help error-proof your production process and achieve your productivity goals

# CW-90 Over/Under Checkweigher Specifications

---

**Power AC:**

Line Voltages: 115/230 VAC

**Frequency:** 50/60 Hz

**Power Consumption:**

1.5 A at 115 VAC (8 W)

0.75 A at 230 VAC (8 W)

**Measurement Rate:**

960, 480, 240, 120, 60, 30, 15, 7.5  
per second

**System Linearity:**

±0.01% full scale

**Digital I/O:**

Four channels on CPU board

**Circuit Protection:**

RFI, EMI, ESD protection

**Display:**

Large 0.8 in, 14 segment, six digit  
high-intensity red LED display

**Scale Frame:**

AISI304L, straight line finish,  
Ra=45 ± 10

**Scale Cover:**

AISI304L, straight line finish,  
Ra=45 ± 10

**Annunciators:**

Designators for %, kg, gm, lb, oz,  
center of zero, G/B, N, T, PT, neg,  
motion

**Operating:**

Legal: 14 °F to 104 °F (-10 °C to 40  
°C)

**Rating/Material:**

IP66, stainless steel

**Resolution:**

Display: 100,000

**Load Cell:**

Aluminum, environmentally sealed

**Warranty:**

Two-year limited

**Approvals:****Indicator:**

NTEP 08-092, Class III/IIIL 10,000  
d

Measurement Canada AM-5710,

Class III 10,000 d

OIML R76/2006-GBI-10.02

TC11569

cULus listed

CE marked

**Scale:**

NTEP 95-072, Class III 5,000 d

Measurement Canada AM-5082

NSF

# CW-90 Over/Under Checkweigher Dimensions

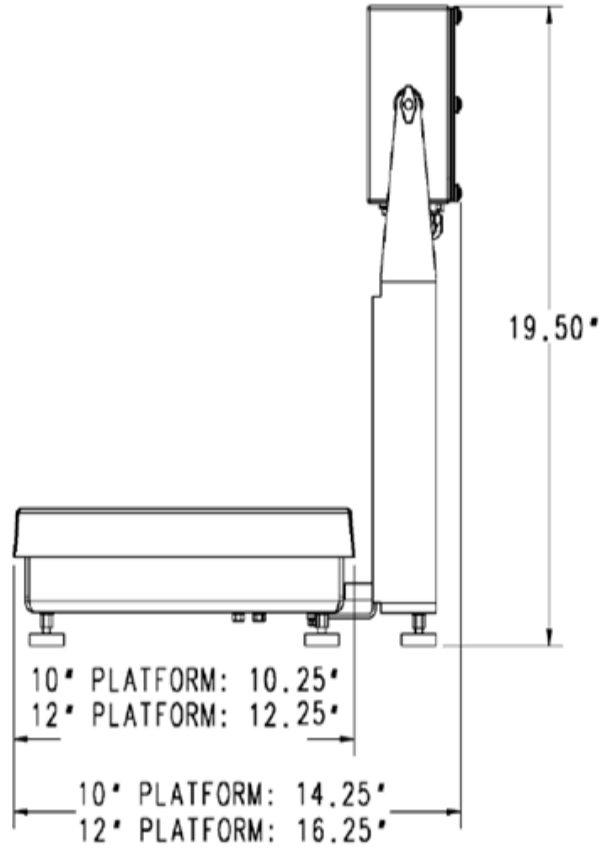
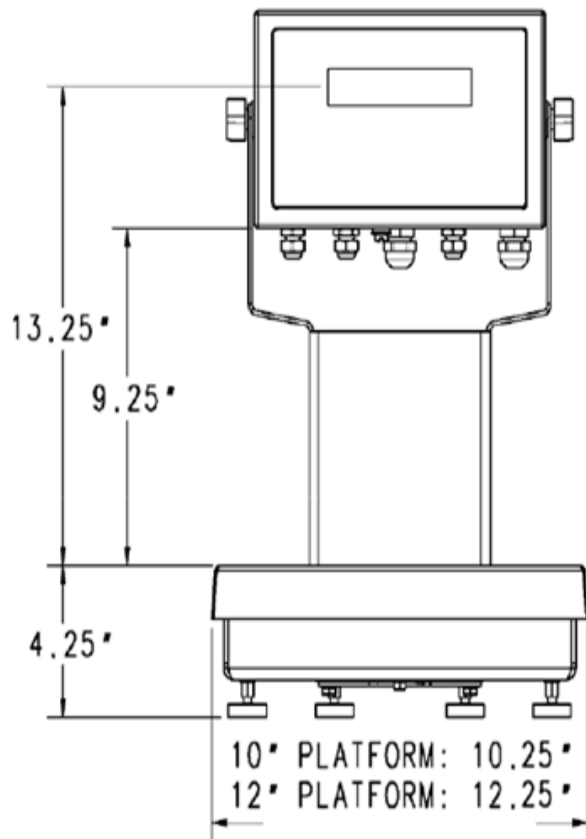

# Parts

---

## Part # Description

### 115 VAC

105957	CKWGHHER, CW90 10X10 5 lb/2.5 kg with 12 inch column 115VAC SST
105958	CKWGHHER, CW90 10X10 10 lb/5 kg with 12 inch column 115VAC SST
105959	CKWGHHER, CW90 10X10 25 lb/10 kg with 12 inch column 115VAC SST
105960	CKWGHHER, CW90 12x12 25 lb/10 kg with 12 inch column 115VAC SST
105961	CKWGHHER, CW90 12x12 50 lb/25 kg with 12 inch column 115VAC SST
105962	CKWGHHER, CW90 12x12 100 lb/50 kg with 12 inch column 115VAC SST

### 230 VAC

118891	CKWGHHER, CW90 10X10 5 lb/2.5 kg with 12 inch column 115-230VAC SST
118892	CKWGHHER, CW90 10X10 10 lb/5 kg with 12 inch column 115-230VAC SST
118893	CKWGHHER, CW90 10X10 25 lb/10 kg with 12 inch column 115-230VAC SST
118895	CKWGHHER, CW90 12X12 25 lb/10 kg with 12 inch column 115-230VAC SST
118896	CKWGHHER, CW90 12X12 50 lb/25 kg with 12 inch column 115-230VAC SST
118897	CKWGHHER, CW90 12X12 100 lb/50 kg with 12 inch column 115-230VAC SST

### 230 VAC (CE marked/OIML approved)

106123	CKWGHHER, CW90 254x254 mm 3 kg with 305mm column 230VAC SST European Version CE and OIML marked with European plug
106124	CKWGHHER, CW90 254x254 mm 6 kg with 305mm column 230VAC SST European Version CE and OIML marked with European plug
106125	CKWGHHER, CW90 254x254 mm 15 kg with 305mm column 230VAC SST European Version CE and OIML marked with European plug
106126	CKWGHHER, CW90 305x305 mm 15 kg with 305mm column 230VAC SST European Version CE and OIML marked with European plug
106127	CKWGHHER, CW90 305x305 mm 30 kg with 304mm column 230VAC SST European Version CE and OIML marked with European plug
106128	CKWGHHER, CW90 305x305 mm 60 kg with 305mm column 230VAC SST European Version CE and OIML marked with European plug

# Options

---

<b>Part #</b>	<b>Description</b>
<b>200578</b>	Ind OPT,Ethernet Interface CW90, CW90X Straight through 10ft ethernet cable with PG11 cord grip
<b>77142</b>	Ind OPT,Ethernet Interface 720i, 820i, iQube, CW90, CW90X
<b>206272</b>	Ind Opt,Wireless LAN Card RS232/WiFi Interface 802.11 A/B 10/100 XPico for CW90,720i,iQube2
<b>171968</b>	Cable,RS-232 5-Wire DB-9F to stripped and tinned leads
<b>96736</b>	Ind Opt,Fiber-Optic Rx/Tx CW90, CW90X, 820i Internal Mount With Bus Power
<b>78026</b>	Cable,Plastic Optical 100 ft. includes polishing kit
<b>80892</b>	Cutter, Fiber Optic Disposable, .750 and 1.0mm single and duplex jacket Industrial Fiber Optics #IF-FC2
<b>117358</b>	Software, WeighVault for CW90/90X License (English)

# Replacement Parts

---

<b>Part #</b>	<b>Description</b>
<b>107756</b>	Load Cell,SPT RL1040-7KG 2.83ft 2mv/v 350 OHM NTEP III 5 S AL Potted FM CE Cable Stripped And Tinned
<b>107757</b>	Load Cell,SPT RL1040-10kg 2.83ft 2mv/v 350 OHM NTEP III 5 S AL Potted FM CE Cable Stripped And Tinned
<b>107758</b>	Load Cell,SPT RL1040-30KG 2.83ft 2mv/v 350 OHM NTEP III 5 S AL Potted FM CE Cable Stripped And Tinned
<b>107759</b>	Load Cell,SPT RL1040-50KG 2.83ft 2mv/v 350 OHM NTEP III 5 S AL Potted FM CE Cable Stripped And Tinned
<b>107760</b>	Load Cell,SPT RL1040- 100KG 2.83ft 2mv/v 350 OHM NTEP III 5 S AL Potted FM CE Cable Stripped And Tinned
<b>107476</b>	Foot,Benchmark 1/4-20NCx 1-1/2 SST USDA/NSF Approved CW90/CW90X
<b>106101</b>	Board Set,CW90_90X Assembled CPU and Display board
<b>105555</b>	Nut,CPLG 1/4-20NC x .400 3/8 Hex With .265 Counterbore SST
<b>105945</b>	Parts Kit,CW-90/CW-90X
<b>14621</b>	Nut,Kep 6-32NC HEX External Tooth Lockwasher Steel Zinc Plated Width Across Flats= 5/16 Thickness=9/64
<b>85202</b>	Power Cord Assy,120VAC W/PG11 Cord Grip And SL-156 Connector UL Certified Power Supply Cord Label Required
<b>85203</b>	Power Cord ASSY,220VAC Continental Europe Plug (CEE7/7) W/PG11 Cord Grip and SL-156 Connector
<b>68600</b>	Cord Grip,PG11 Black For Cable OD .20" - .39"
<b>68599</b>	Seal Ring,Nylon PG-11
<b>68601</b>	Nut,PG11 Cord Grip Black Nylon
<b>58983</b>	Cord Grip,SL7 w/Nut Skintop S2107 Clamping Range = .098 - .256 RoHS Compliant
<b>16892</b>	Label,Ground Protective Earth Adhesive IEC 60417-5019 (DB:2002-10)
<b>15134</b>	Washer,Lock NO 8 Type A Internal Tooth Steel Zinc Plated ID=.168-.176 OD=.325-.340 Thickness=.018-.023
<b>14626</b>	Nut,Kep 8-32NC HEX External Tooth Lockwasher Steel Zinc Plated Width Across Flats= 11/32 Thickness=5/32. 8-32
<b>45043</b>	Wire ASSY,Ground 4 In. 16 AWG Green/Yellow Wire, w/#8 Eye Connector Both Ends
<b>104914</b>	Overlay,Membrane Switch Panel CW90
<b>104915</b>	Keypad, Piezo Switch Panel CW90X
<b>76556</b>	Power Supply,Switching 85-265VAC Input, 7.5VDC Output, 3.3A Max
<b>14822</b>	Screw,MACH 4-40NCx1/4 Phillips Pan Head Internal Tooth Lock Washer SEMS Steel Zinc Plated



<b>Part #</b>	<b>Description</b>
<b>14825</b>	Screw,Machine 4-40NC x 1/4 Phillips Pan Head 18-8 SST with Nylon Patch on Thread
<b>105976</b>	Cable ASSY,Power Supply 1&2=+V 3&4=-V Straight Through
<b>102354</b>	Board,CPU CW90 ROHS Compliant (Battery p/n 69291 not included)
<b>120084</b>	Board,CPU CW90 ROHS Compliant
<b>105741</b>	Board Assy, Display CW90 CW90X Custom LED interface board, w/ piezo & membrane interface
<b>69291</b>	Battery,3v Coin Lithium 16mm Diameter, 125(mAh), Metal
<b>42640</b>	Screw,Mach 1/4-28NF x .25 Phillips, Drilled Fillister Head, 18-8 SST
<b>44676</b>	Washer,Bonded Sealing SST 1/4 ID x 5/8 OD
<b>84388</b>	Gasket,Backplate 680 682 CW90, CW90X, 320IS, 420 indicators
<b>14862</b>	Screw,Machine 8-32NC x 3/8 Phillips Pan Head Fully Threaded 18-8 SST
<b>45042</b>	Washer,Bonded Sealing #8 3/8 (.375) OD SST
<b>29635</b>	Stand,Tilt SST
<b>103988</b>	Washer,Nylon .515 -.52 ID X 1.00 OD x .093 -.094 Thick White Nylon 6/6
<b>103610</b>	Knob,Tee, 1/4-20, Nylon, Brass or SST Insert, Black
<b>16861</b>	Label,Warning High Voltage Adhesive
<b>182479</b>	Vent, Metal Breather Goretex Membrane in M12x1.5 SST Chassis IP69K, ATEX/IECEX approved
<b>182480</b>	Nut, Metal Breather Vent M12x1.5 SST for PN: 182479

**www.ricelake.com | 800-472-6703**

*An ISO 9001 Registered Company ©2024 Rice Lake Weighing Systems*